

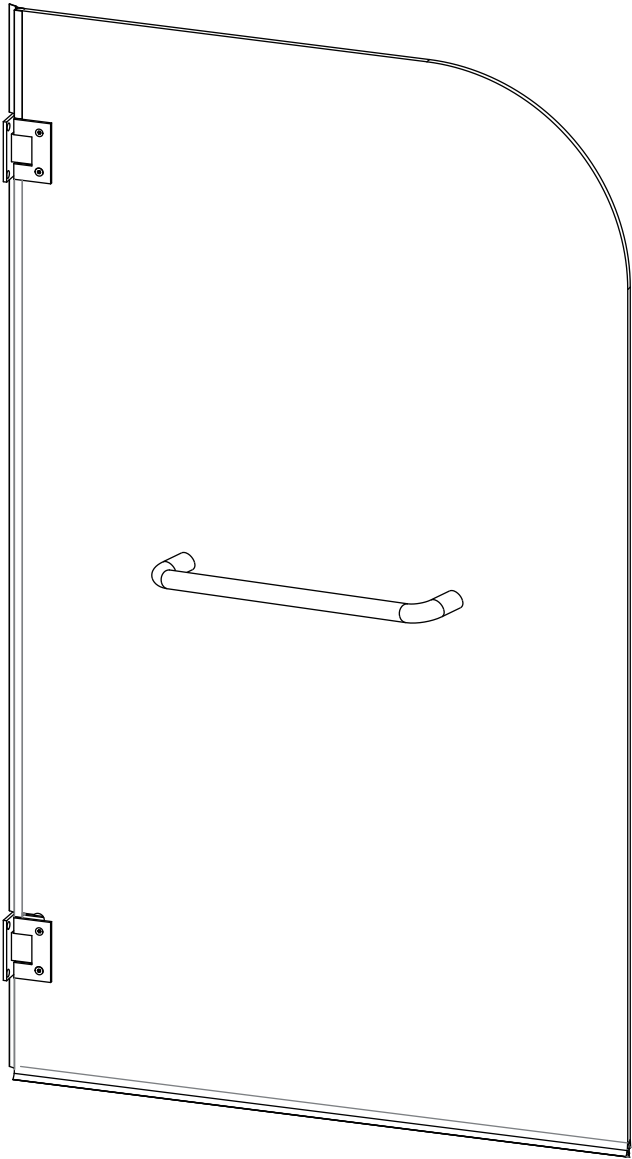

**INSTALLATION INSTRUCTIONS**

**BSV3662G**



## ◆ General Information

Inspect the product immediately upon receipt for transit damage, missing packs/parts or manufacturing fault. Damage reported later will not be accepted. Handle the product with care avoiding knocks and shock loading to all sides and edges of the glass.

**Notes: Safety glass can not be re-worked.**

Read these instructions carefully before start of installation.

Special care should be taken when drilling walls to avoid hidden pipes or electrical cables

Note: This product is heavy and may require two people to install.

## Aftercare instructions

After use, your shower should be cleaned with soap and water. This is particularly important in hard water districts where insoluble lime salts maybe deposited and allowed to build up. Cleaners of a gritty or abrasive nature should not be used. Care should be taken to avoid contact with strong chemicals, they can be used but with caution, if in doubt contact the manufacturer of the cleaner in question.

Keep these instructions for aftercare and customer service details.

---

## Tools Required

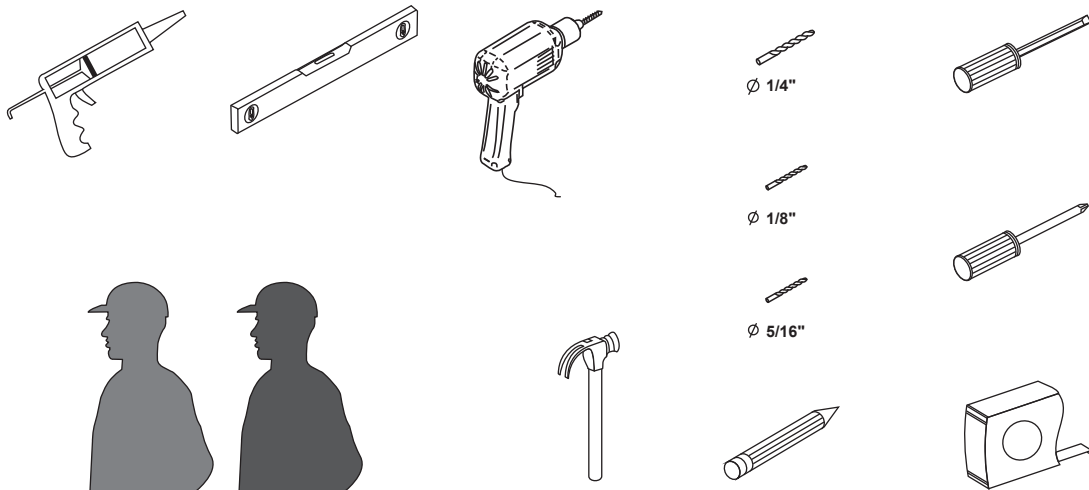

**This product is heavy and may require two people to install.**



## ◆ Assembly Drawing

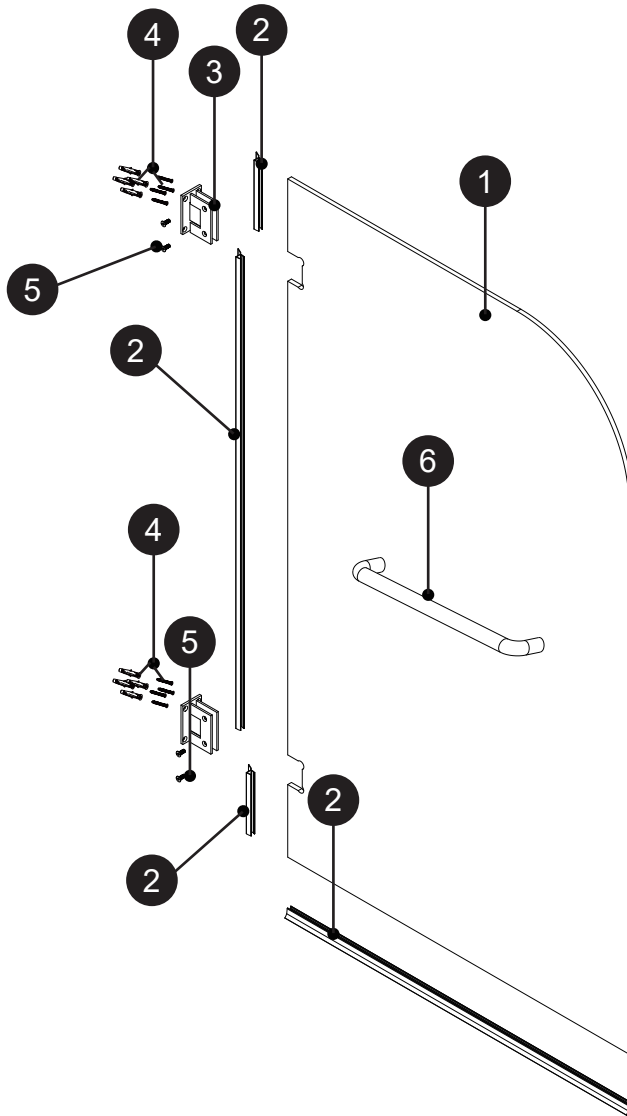

## PACKING LIST

PART	DESCRIPTION	Q'TY	PART	DESCRIPTION	Q'TY
1	Glass	1pcs	9		
2	Plastic Gaskets	4pcs	10		
3	Hinges	2pcs	11		
4	Wall Plug	2pcs	12		
5	M6 screws	4pcs	13		
6	Towel Bar	1pcs	14		
7			15		
8			16		

# ◆ Installation Steps

## Step 1

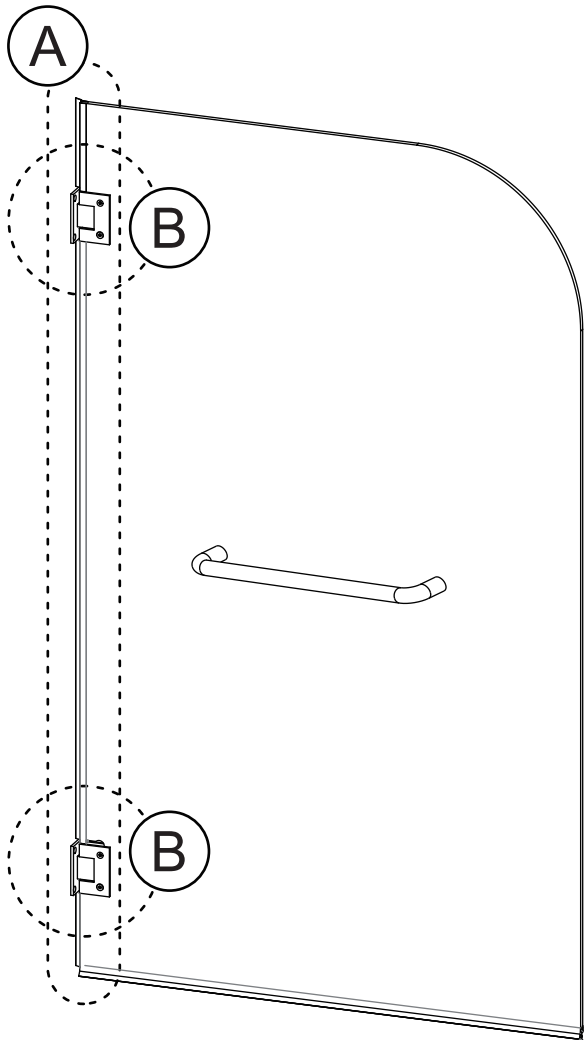

View from outside

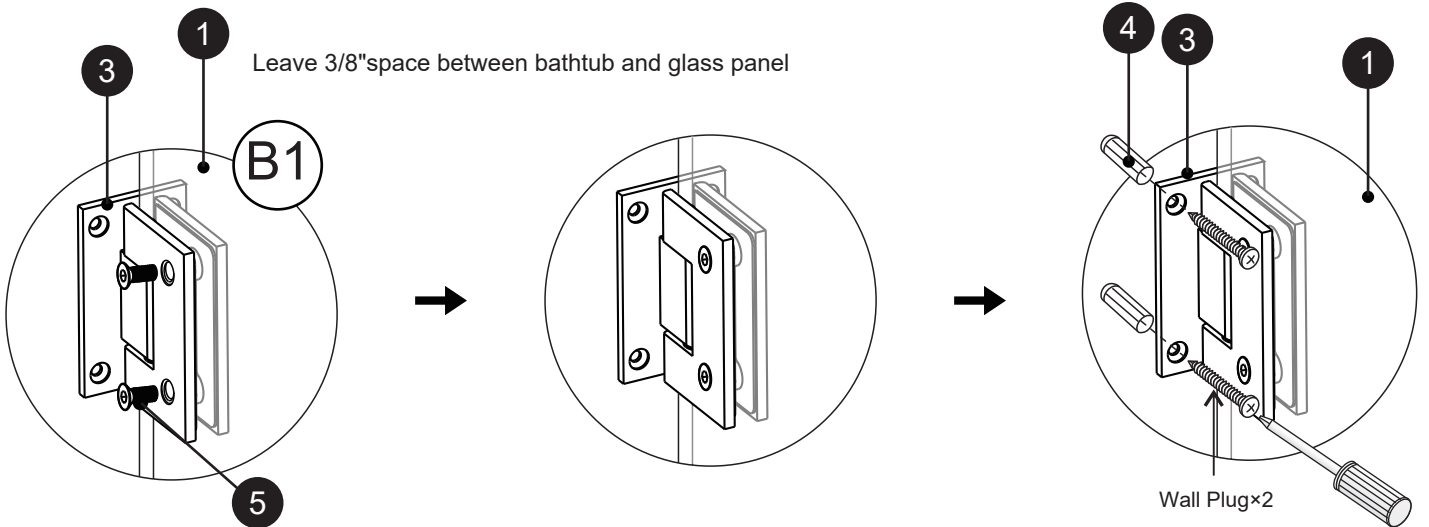
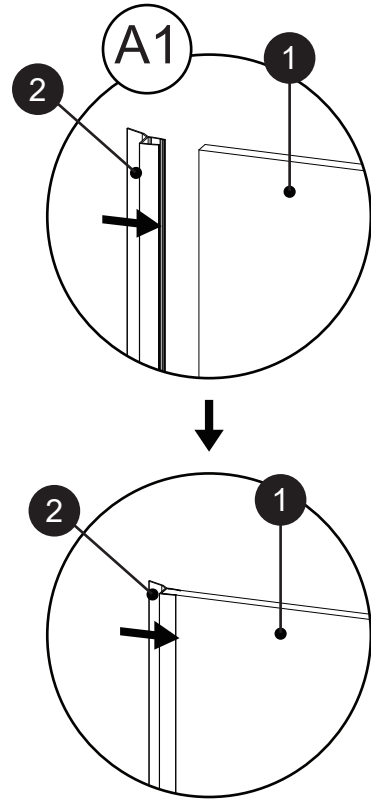

# Step 2

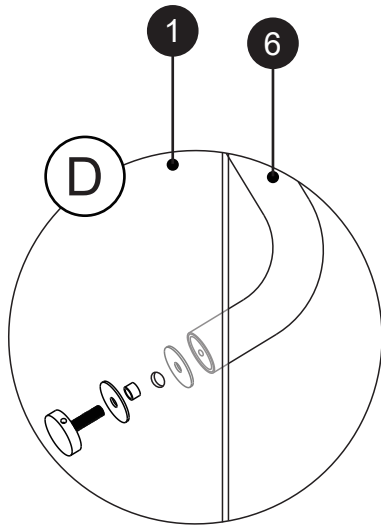
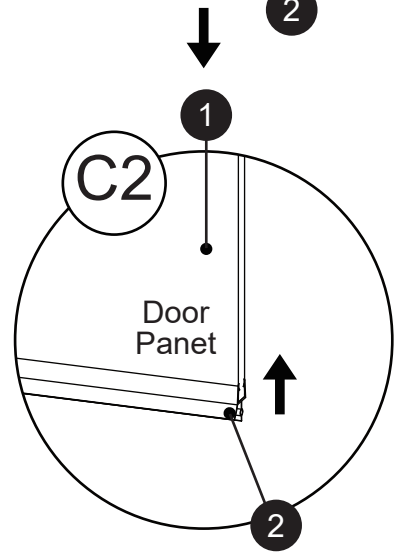
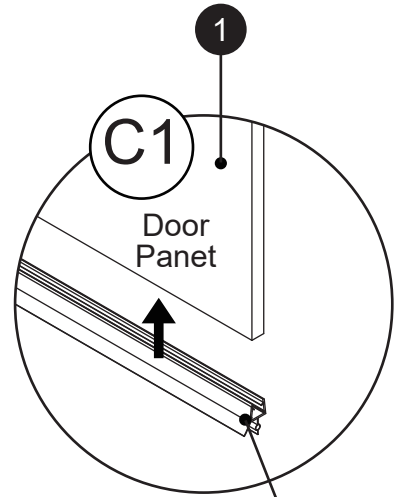
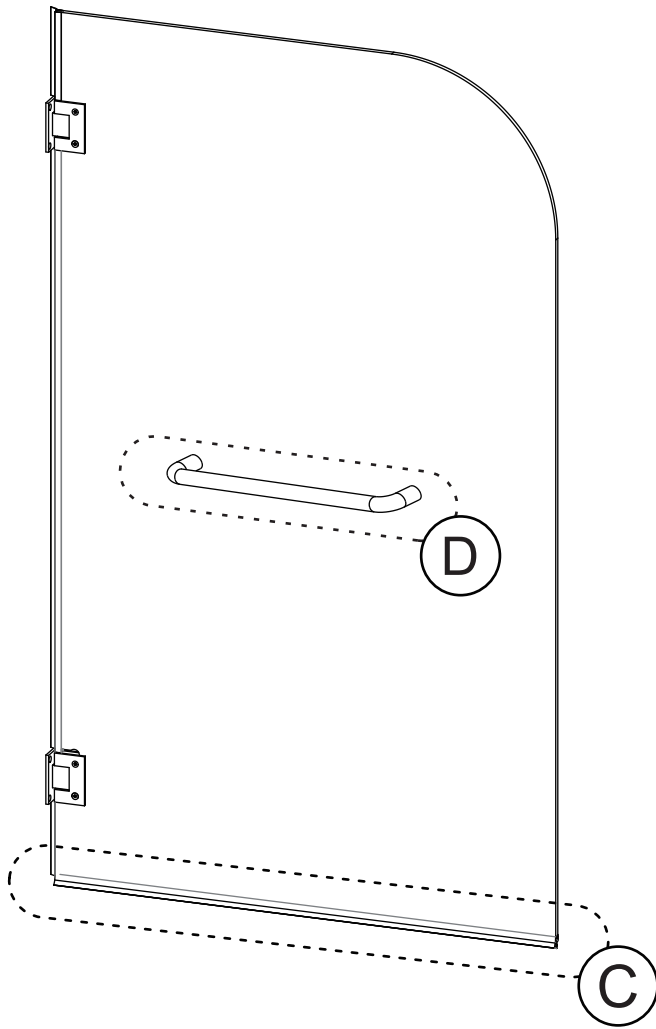

**View from inside**

## **VEETRO EXCLUSIVE LIMITED WARRANTY**

This warranty applies to Veetro Shower Doors ("Veetro") products purchase after Oct 1st, 2023.

Veetro offers the following warranty for its products and components thereof. This warranty extends only to the original owner/end-user for household use only and is not transferable to a subsequent owner. Veetro reserves the right to modify this warranty at any time, it being understood that such modifications will not alter the warranty conditions applicable at the time of sale of the products in question. This warranty extends for a designated period of time, so long as the product remains in use in its original place of installation. This warranty applies only to Veetro products purchased from an authorized dealer in the California, United States. Proof of purchase (original sales receipt) from the original consumer purchase must be provided with all warranty claims. No responsibility is assumed by Veetro for any special, incidental or consequential damages. **IN NO EVENT SHALL THE LIABILITY OF Veetro EXCEED THE PURCHASE PRICE OF THE UNIT.**

Veetro products must be installed by a fully insured, licensed professional and according to the Veetro installation instructions. Installation of Veetro product by anyone other than a fully insured licensed professional shall VOID THE WARRANTY. Veetro recommends that such licensed professionals have experience in the installation of bathroom (specifically shower and tub doors) products. Installation of certain products, including, without limitation, glass products (i.e., shower and tub doors) by an unlicensed or inexperienced installer may result in glass breakage and, consequently, may cause personal injury or even death.

### **PARTS ONLY WARRANTY**

This warranty is extensive in that it covers replacement of all defects. LABOR CHARGES AND/OR DAMAGE INCURRED DURING INSTALLATION, REPAIR, OR REPLACEMENT, AS WELL AS ANY OTHER KIND OF ANCILLARY COST, LOSS OR DAMAGE ARE EXCLUDED.

### **COMMERCIAL USE AND OTHER EXCLUSIONS**

This warranty excludes all industrial, commercial and business usage. The warranty period for products installed for commercial applications or used in commercial ventures, including but not limited to motels, hotels, casinos, student housing, condos, apartments, and fitness centers, is a one (1) year limited warranty from the date of purchase for shower doors, bathtub doors, shower enclosures, and shower bases, with all other terms of this warranty applying except the duration of the warranty. Veetro hereby disclaims all warranties for products sold as dealer or store displays. Veetro hereby disclaims all warranties for products used outside of the California, United States whether expressed or implied, including but not limited to the implied warranties of merchantability and fitness for a particular purpose.

### **WARRANTY TERMS**

Veetro Shower Doors will, at its election, repair or replace the product found by Veetro in its sole judgment, to be defective within the warranty period under normal residential use and maintenance. The replacement of a product is limited to supplying a replacement product or part (same as existing or if not available, comparable product). Veetro warranty obligation shall be discharged upon tender of parts, replacement or repair of the product. Purchaser's refusal to accept the tender terminates all warranty obligations and VOIDS THE WARRANTY. Cost of freight for returning products to Veetro for repairs or replacement under this limited warranty are the responsibility of the customer. Cost of freight associated with shipping of replacement product(s) or parts covered by this warranty is the responsibility of the original user. Any product replaced or repaired during the warranty period will be covered only for the remaining period of the original warranty. In no event will Veetro be liable for costs of repair or replacement of any installation material, including but not limited to tile, marble, etc. **VEETRO IS NOT RESPONSIBLE FOR INSTALLATION, REMOVAL OR REINSTALLATION COSTS OF ANY PRODUCT REQUIRING WARRANTY SERVICES.**

Any modification or alteration of any Veetro products will void the warranty. Neither the authorized Veetro dealer, nor any other person is permitted to make any affirmation, representation, or warranty other than those contained in this warranty. Any affirmation, representation, or warranty other than those contained in this warranty shall not be enforceable against Veetro or any other person.

Veetro product installations and repairs must be performed by a licensed, insured and experienced professional contractor - installation or repairs performed by any other party shall void the warranty. This warranty shall not apply to breakage or damages caused by normal wear and tear, fault, carelessness, abuse, misuse, misapplication, improper maintenance, alteration or modification of the unit, as well as chemical or natural corrosion, accident, fire, flood, act of God or any other casualty. Improper care and cleaning will void the warranty. Use of cleaners containing abrasive cleansers, ammonia, bleach, acids, waxes, alcohol, solvents or other products not recommended for hardware finishes, glass or acrylic as they may damage the metal or glass finish of your shower door or shower enclosure and will void the warranty. For additional product maintenance instructions please refer to the product installation manual.

Veetro is not responsible for any issues arising in connection with errors or omissions in information provided on Veetro or dealers' websites. This warranty does not extend to any non- Veetro plumbing or components installed by installers, end users or by any party other than Veetro.

**THE FOREGOING WARRANTIES ARE IN LIEU OF ALL OTHER WARRANTIES, EXPRESSED OR IMPLIED, INCLUDING BUT NOT LIMITED TO THE IMPLIED WARRANTIES OF MERCHANTABILITY AND FITNESS FOR A PARTICULAR PURPOSE. Veetro SHOWER DOORS LLC ("Veetro") AND/OR SELLER DISCLAIMS ALL LIABILITY FOR SPECIAL, INCIDENTAL OR CONSEQUENTIAL DAMAGES. Veetro IS NOT LIABLE FOR PERSONAL INJURIES OR DEATH TO ANY PERSON OR FOR ANY DIRECT, SPECIAL, INCIDENTAL OR CONSEQUENTIAL DAMAGE, LOSS OF USE, LOSS OF TIME, LOSS OF PROFITS, INCONVENIENCE, INCIDENTAL EXPENSES, LABOR OR MATERIAL CHARGES, OR ANY OTHER COSTS RESULTING FROM THE USE OF ITS PRODUCTS OR PERTAINING TO THE APPLICATION OF THE PRESENT WARRANTY, OR RESULTING FROM THE REMOVAL OR REPLACEMENT OF ANY PRODUCT OR ELEMENT OR PART COVERED BY THIS WARRANTY.**

## **PRODUCT WARRANTY PERIODS**

The laws and regulations that govern the installation and use of shower or tub doors, shower enclosures and shower bases vary widely by region, state or municipality. Except as otherwise provided above, Veetro makes no warranties, expressed or implied, including warranties of merchantability and fitness for a particular purpose or compliance with any code. Veetro is not responsible for verifying building code restrictions on installation or use and any such compliance is excluded from this warranty. Veetro reserves the right to modify this warranty at any time - such warranty modifications will not alter the warranty applicable at the time of sale of the products in question. The warranty terms for specific products for consumer (nonindustrial, non-commercial, non-business use only) are:

### **SHOWER & TUB DOORS, SHOWER ENCLOSURES**

Veetro shower doors, tub doors, and shower enclosures are backed by a Limited Two (2) Years Warranty. Veetro warrants the parts of shower doors, tub doors and shower enclosures to be free from defects in workmanship and materials under normal residential use for a period commencing from the initial date of purchase by the owner/end-user, contractor or builder from an authorized Veetro dealer for two years of the product as long as the original consumer purchaser owns the home in which the product is installed. Warranty for plastic seal strips, sweeps or any other vinyl components shall be limited to one (1) year. Veetro does not warrant glass for scratches, chips, water spots, breaking or any other damage after installation.

### **SHOWER & TUB DOORS, SHOWER ENCLOSURE HARDWARE**

Veetro shower door, tub door, and shower enclosure hardware is backed by a Limited Two (2) Years Warranty. Veetro warrants shower door, tub door and shower enclosure hardware (i.e. handles, rollers, hinges, profiles, clips, guides, brackets, towel and support bars) in chrome and brushed nickel finish only to be free from defects in workmanship and materials under normal residential use for a period commencing from the initial date of purchase by the owner/end-user, contractor or builder from an authorized Veetro dealer for two years of the product as long as the original consumer purchaser owns the home in which the product is installed. Warranty for any part in matte black and satin gold finish shall be limited to one (1) year.

### **SHOWER BASES**

Veetro warrants shower bases purchased by the owner/end-user, contractor or builder from an authorized Veetro dealer to be free from defects in workmanship and materials under normal residential use for two years of the product as long as the original consumer purchaser owns the home in which the product is installed.

## **WARRANTY SERVICE**

In order to obtain service provided under this warranty, first contact the dealer or distributor who sold this unit. Veetro Shower Doors will provide the warranty service described above when the following conditions has been met: The failure is of the nature or type covered by the warranty; The user has informed an authorized Veetro agent or Veetro's warranty service representative of the nature of the problem during the warranty period; Conducive evidence (e.g., proof of purchase or installation) is provided to the foregoing by the user proving that the failure occurred or was discovered within the warranty period; An authorized service person or company representative has been permitted to inspect the product during regular business hours within a reasonable time after the problem was reported by the user. Veetro's warranty obligation shall be discharged upon tender of replacement or repair. The customer's refusal to accept the tender voids Veetro's warty obligations.

Email: [info@veetroglass.com](mailto:info@veetroglass.com)

Mailing Address: Veetro Shower Doors LLC  
23511 BERNHARDT ST, #B  
HAYWARD, CA 94545

Or, contact the Technical Support Center Monday thru Friday 10:00 am – 4:00 pm PST Technical Support: 1-510-400-9884

## **Product Maintenance**

**BASES:** To ensure long lasting life for your acrylic bases: wipe them off after each use with a soft cloth. To clean the acrylic bases use non-abrasive sprays or cream based cleaners. Avoid the use of aerosol spray cleaners. Never use abrasive cleansers, metal brushes or scrapers that could scratch or dull the surface.

**GLASS:** To ensure long lasting life for your glass shower products: wipe them off after each use with a soft cloth. Rinse and wipe off the glass using either a soft cloth or a squeegee to prevent soap buildup and water spots (Hard water can etch the surface of the glass over time if left to dry). To prevent scratching the surface: never use abrasive cleaners or cleaning products that contain scouring agents. Never use bristle brushes or abrasive sponges that may scratch the surface.

**HARDWARE:** To ensure a long lasting finish: wipe off the metal parts after each use with a soft cloth. Do not use abrasive cleaners or cleaning products containing ammonia, bleach or acid. If accidentally used, rinse the surface as soon as possible to prevent damage to the finish (peeling or corrosion). After cleaning the polished finishes, rinse thoroughly and wipe dry with soft cloth. Clean stainless steel surfaces at least once a week. When applying stainless steel cleaner or polish to stainless steel hardware, work with (not across) the grain. Never use an abrasive sponge or cloth, steel wool or wired brush as these may permanently scratch the surfaces.